



COPPER WIRE ROD

Higher Performance with Greater Reliability



THE WORLD BEST CABLE SOLUTION LEADER

LS Cable & System supplies various cables and materials used for power grids and communication networks around the world across all industries providing its top class technology and excellent quality. The company has also developed state of the art products, such as superconductors, HVDC and submarine cables that will lead the future energy industry.

LS spun off from LG in 2003 as a group specializing in electronics, electrical systems, energy and materials.



LS Cable & System

Transmission Cable
Distribution Cable
Submarine Cable
Telecommunication Cable
Industrial Cable
Industrial Material

LSELECTRIC

Electric &
Automatic Equipments

LS-Nikko Copper

Copper Refinement

LS Mitron

Mechanical &
Electronic Parts

yesco
LNG

E1
LPG

GBON
Power &
Communication
Cables

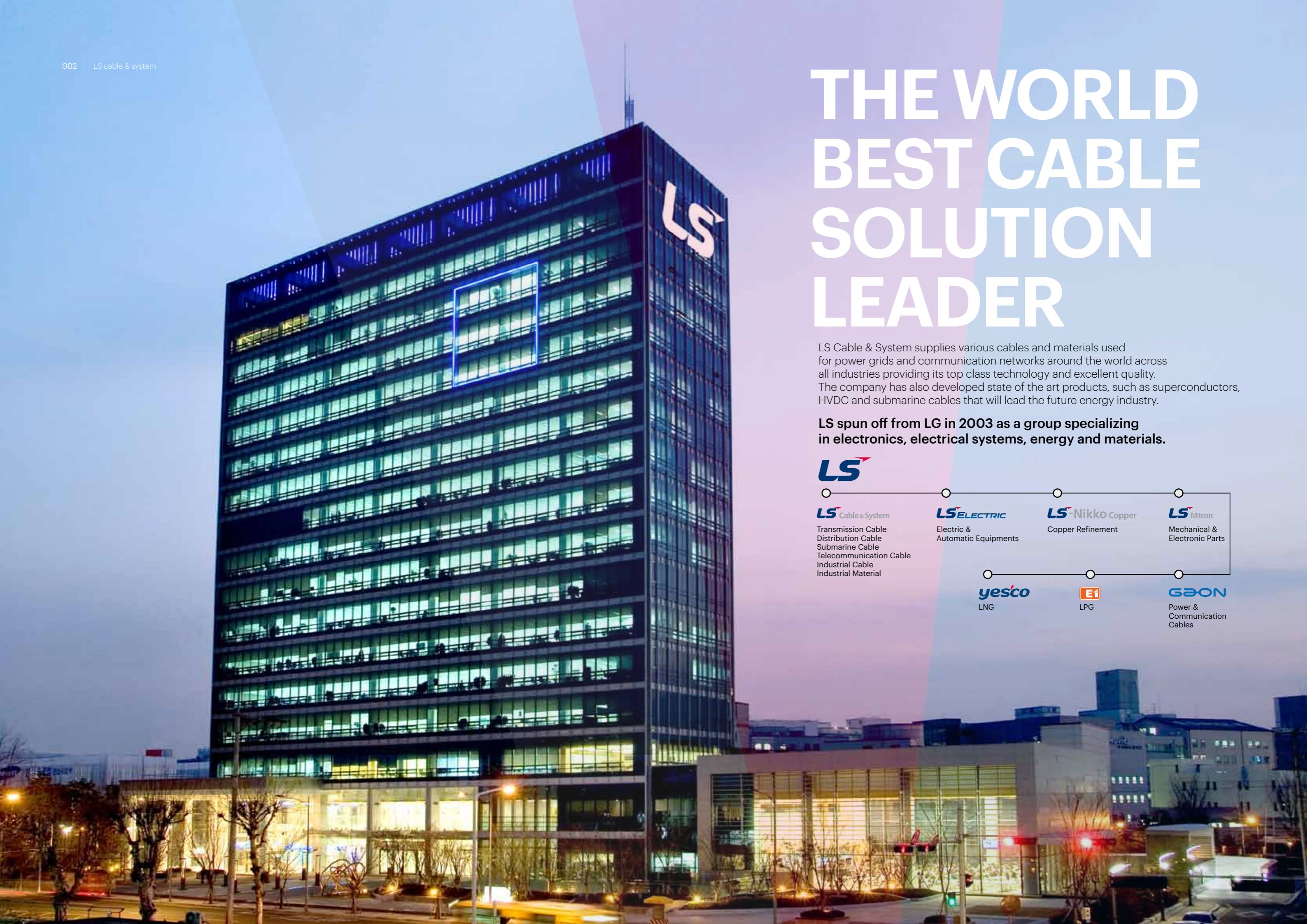



LS Copper Wire Rod

To address the ever-changing demands in everyday life as well as in the industry, LS Materials, a division of we never stop researching, designing, developing, and manufacturing products with the higher level of quality. Our quality control meets the most delicate requirements of international standards and the high level of quality is recognized both by local and international clients: LS Materials is the leading manufacturer and supplier in the market. Our commitment to develop and deliver solutions to address our customers' needs and challenges keep our technology on the cutting edge and our know-how in the field more valuable, which our clients highly appreciate.

Milestones

- 2005 Certificate Quality assurance system; ISO 16949 Launched
- 2002 Certificate Quality assurance system; ISO 14001 Launched
- 1997 Certificate Safety & Health management system; KOSHA 18001
- 1996 Up-Grade SCR Line to 270,000 MT/Year
- 1996 Up-Grade SCR Line to 240,000 MT/Year
- 1994 Certified Quality assurance system as per UL ISO 9001 Launched
- 1993 Computerized Automatic process control system
- 1991 Computerized quality assurance system
- 1988 Up-Grade SCR Line to 180,000 MT
- 1980 Commisioning Southwire SCR Line With 98,000 MT/Year



Special Features

LS Materials produces copper wire and rod with a standard diameter from 2.6mm to 23.0mm, which has following features :

- Uniform microstructure with smooth surface
- Well-controlled oxygen content level and dispersion
- Customer-oriented quality control
- Total solution for minimum wire breaks
- Prompt and Just-In-Time delivery system

Supported by the excellent features above, our clients rarely experience wire breaks, which could deteriorate the performance and cause the loss of time in the process of production. The best excellency in drawability of our products is proved in the real world practice by many of our clients, who use multi-drawing machine to make flexible conductor for automotive wire under high speed with rare wire breaks.



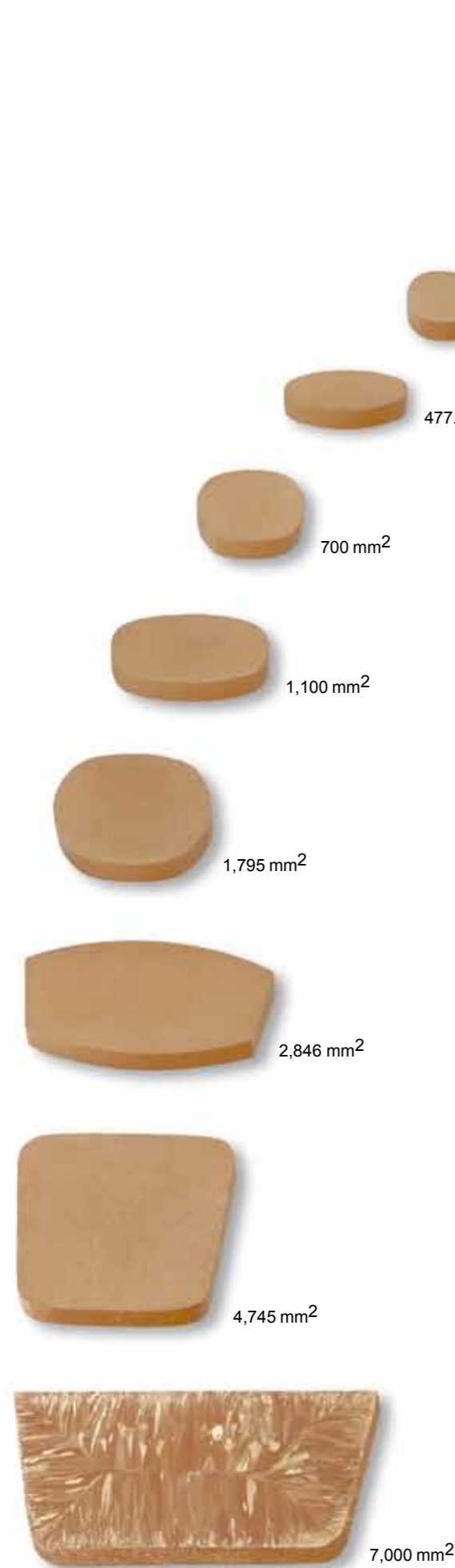

The Process of LS SCR Copper Rod System

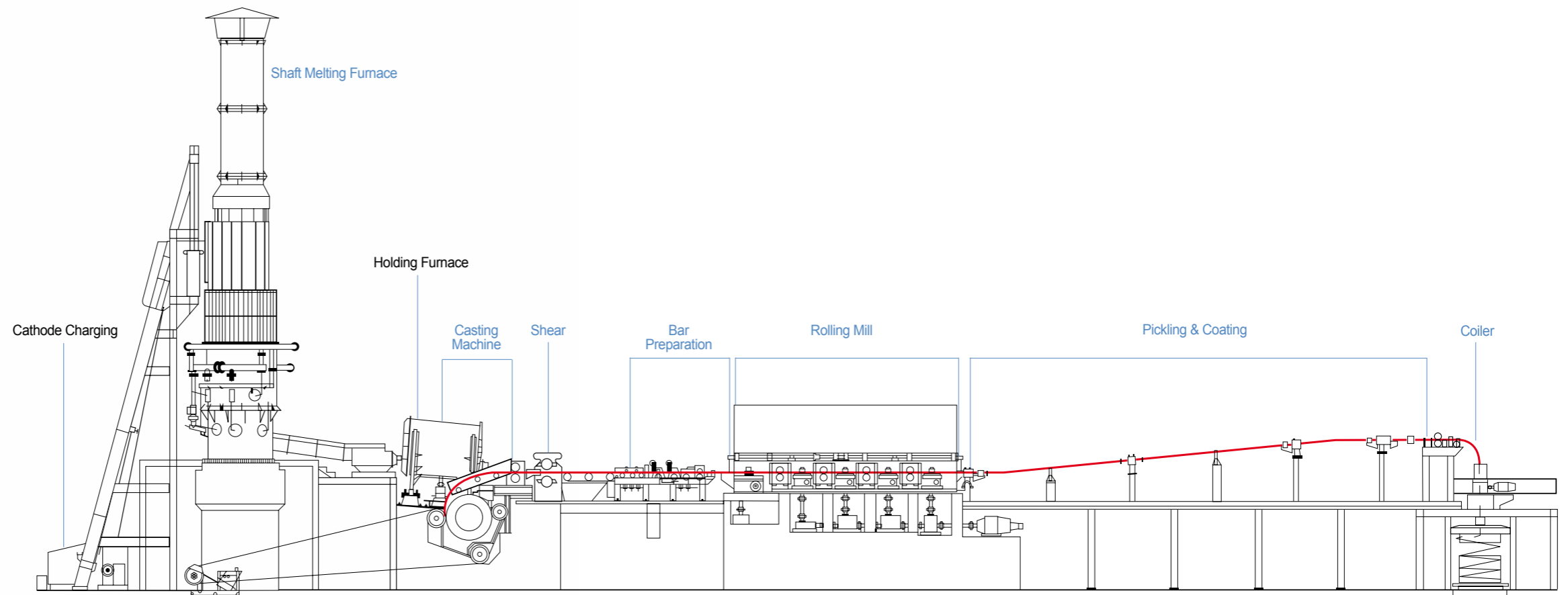

Quality Control & Assurance

Equipped with the Southwire Continuous Rod System, LS Materials holds a certificate compliant with the following standards : ISO 14001 and ISO 9001 and we are proud to be a Sony Green Partner.

Our quality management features in :

- High quality copper cathode (Selected brand of LME Grade 'A')
- Computerized operation for optimum parameter control
- In-line detector for whole length quality assurance
- Destroy test by sampling for every six coils
- Total Production Maintenance for highly efficient facility condition

Standards

KSC 3133, ASTM B49/92 and customers' requirements

Dimension & Application

Diameter (mm)	Application
*2.0	Ultra super fine enameled wire
**2.6	Automotive wire / Enameled wire
8.0	Automotive wire / Enameled wire / Communication cable / Power cable
9.5	Strip flat wire
12.7	Strip flat wire
18.0	Strip flat wire / Trolley wire
23.0	Trolley wire

* Shaved drawn copper wire

** Drawn copper wire (Hard / Annealed)

Mechanical Properties

Elongation : Min. 30%

Tensile strength : 23.46 Kg/mm² (for reference)

Electrical Properties

Resistivity : Max 0.15328 Ω · g/m² at 20°CΩ

Conductivity (at 20°C) : Min. 100% IACS

Chemical Properties

Cu purity : Min. 99.90% (Typically 99.97%)

Chemical Composition

	Fe	Ni	Zn	Mn	Co	Sn	Pb	Bi	Sb	Te	Ag	As	Cr	S	Max.	O ₂
ASTM B49/92	10	10	-	-	-	5	5	1	4	2	25	5	-	15	65	100-650
Typical (ppm)	6.9	0.2	0.3	0.3	0.2	0.2	0.6	0.1	0.2	0.1	5.2	0.2	0.1	5	19.6	263

Coiling & Packing

Orbital Coiling System presents the solution of the tangling problem even higher drawing speed than 1,000 meter per minute. Packing with highly controlled system can prevent oxidization during transportation and keep the goods with shiny and smooth surface.

8.0mm

- Coil weight : Max. 4.5 metric tons per pallet (20 metric tons per 20-foot container)
- Inside diameter : 950 mm
- Outside diameter : 1,600 mm
- Height : 700 mm
- Dimension of pallet : 1,550 x 1,550 x 150 (H) mm

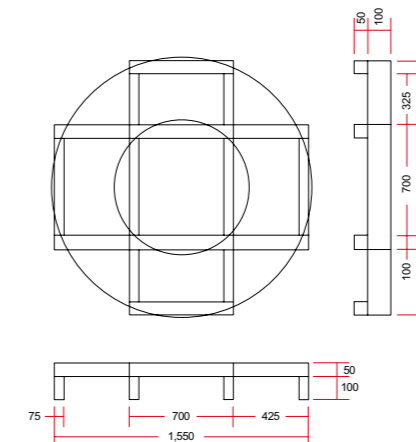

2.6mm

- Inner Box Size : 650 X 650 X 1,750 mm
Type : 700G / Octagon-SF
- Outer Box Size : 1,120 X 1,120 X 1,750 mm
Type : 700G / Octagon
- Net Weight : Max. 1,800 kg

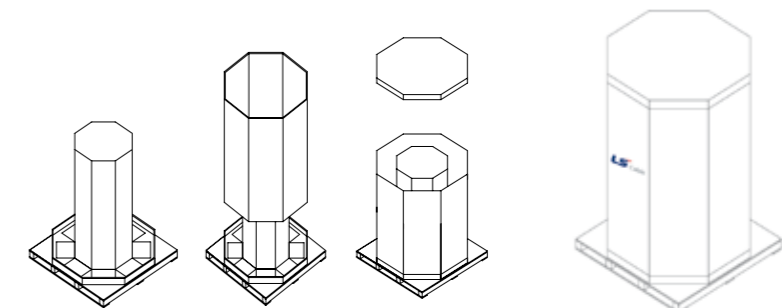



www.lscns.com
Copper Wire & Rod Business Team

12-17F, LS Tower, 127, LS-ro, Dongan-gu, Anyang-si, Gyeonggi-do, 14119, Korea
Tel. 82-2-2189-9192

©2020 LS Cable & System Ltd. All right reserved.

This product or document is protected by copyright and distributed under licenses restricting its use, copying, distribution, and recompilation. No part of this product or document may be reproduced in any form by any means without prior written authorization of LS Cable&System and its licensors, if any.

Products shown on this catalog are subject to change without any prior notice.